

Unpacking the blind and preparing the window

1

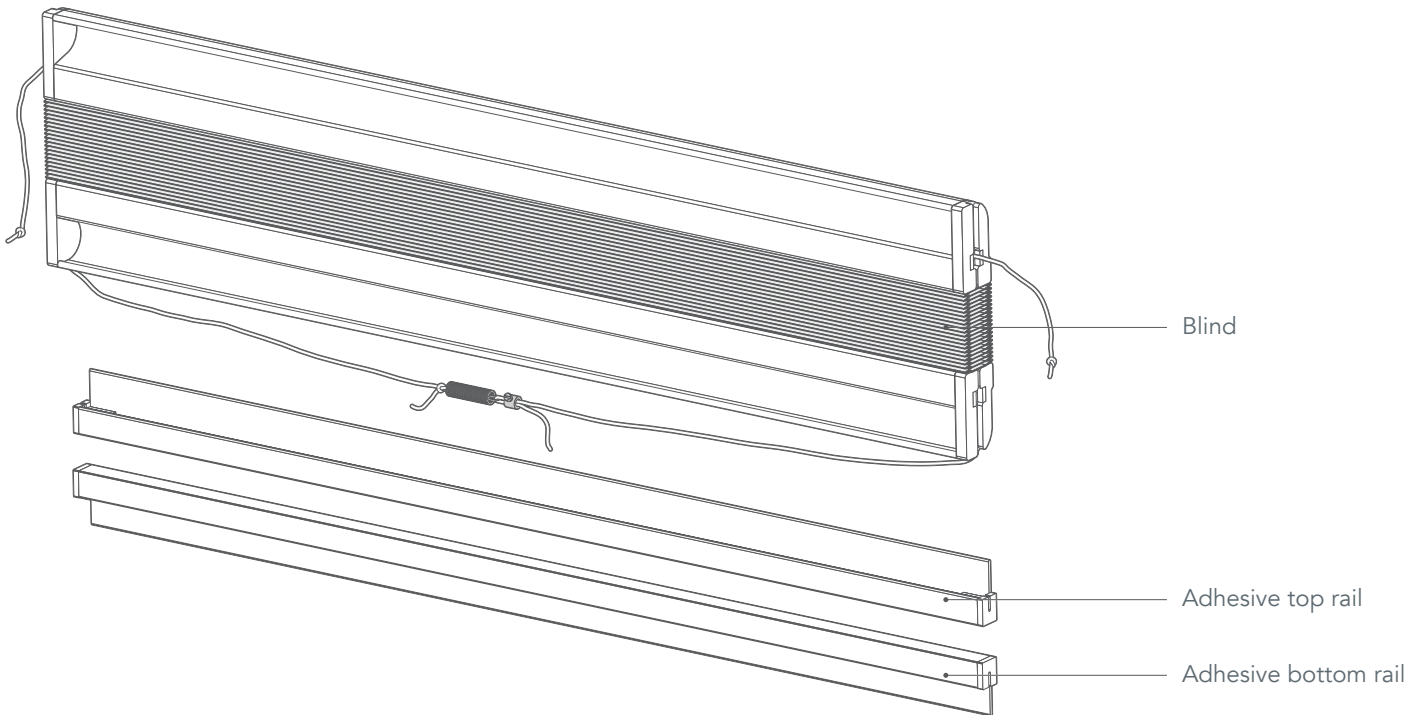

When you first unwrap the blind you'll find that it's in 3 parts - the blind itself, and the top and bottom adhesive rails from which the blind will be suspended.

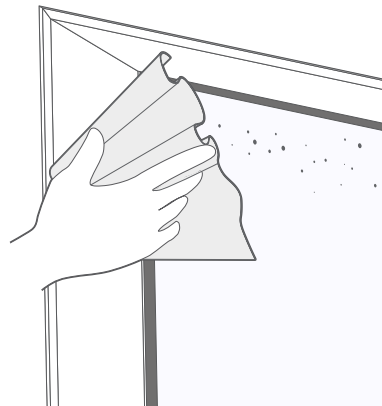

Prepare the windows you'll be fitting the blinds to by giving them a thorough clean, especially at the top and bottom. Give it some time afterward to make sure the glass is fully dry before fitting the blind.

Fitting the adhesive rails

2

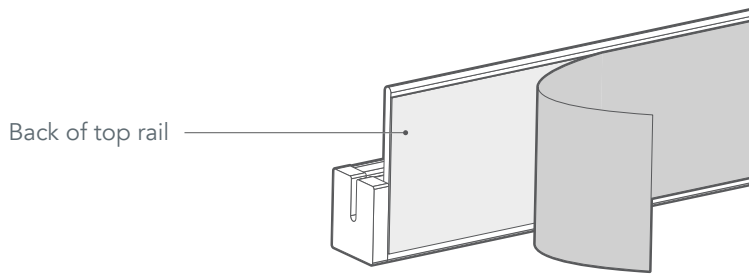

On the back of the top and bottom rails is an adhesive strip. Peel the adhesive cover from the strip on the top rail.

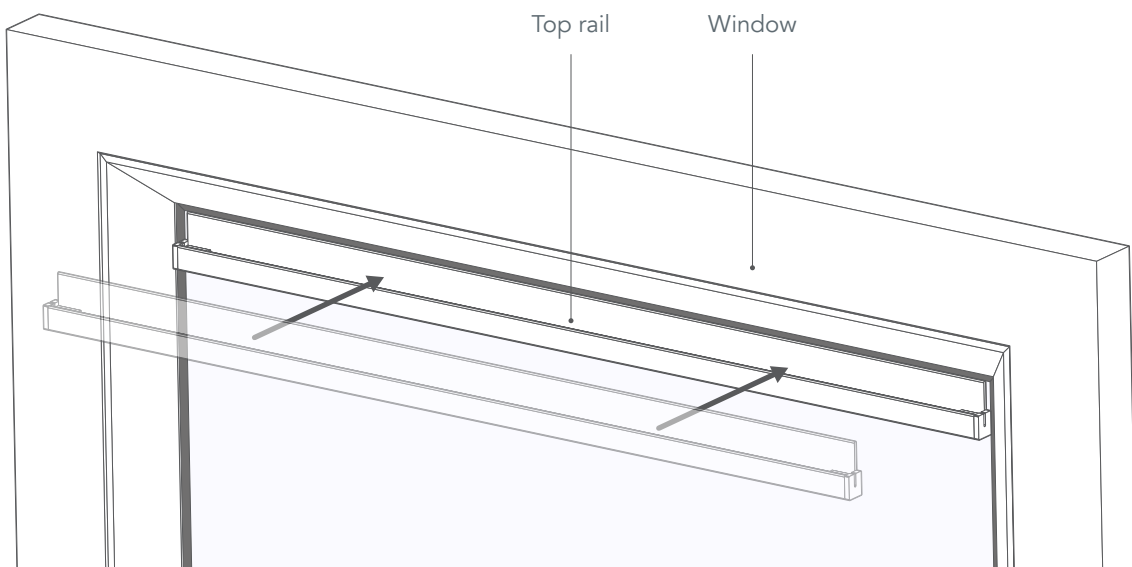

Carefully line up the top rail with the top of the visible glass. Make sure that the top of the top rail is flush with the edge of the rubber seal, if the seal is visible, or the edge of the frame if it is not.

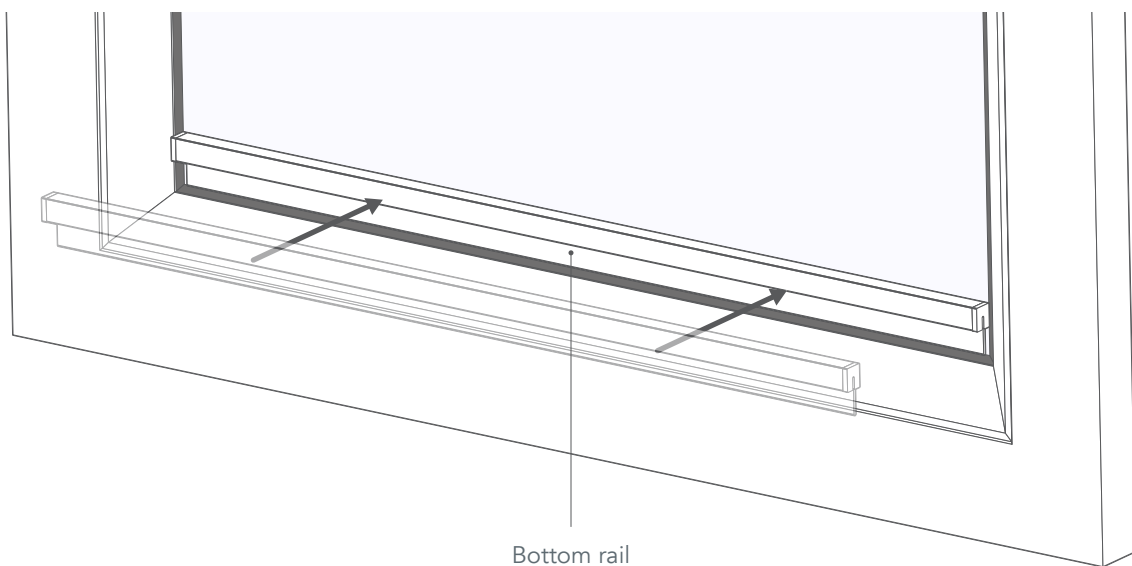

Repeat the process for the bottom rail.

Fitting the blind

3

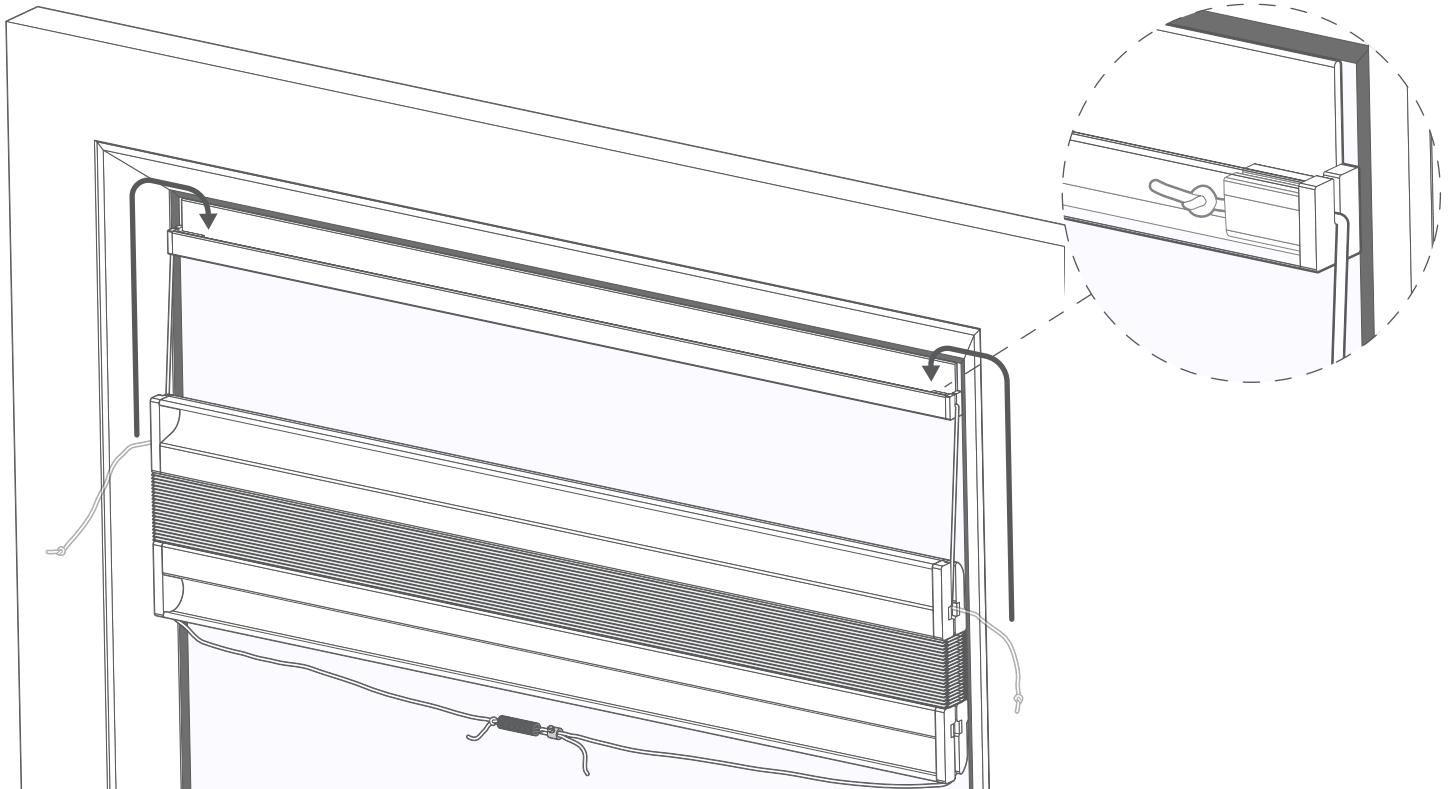

Lift the blind into the window, then take the two knotted ends of the cords at either side, and hook each knot over and into the slots at the ends of the top rail, so that the blind is suspended from the top rail by those two cords.

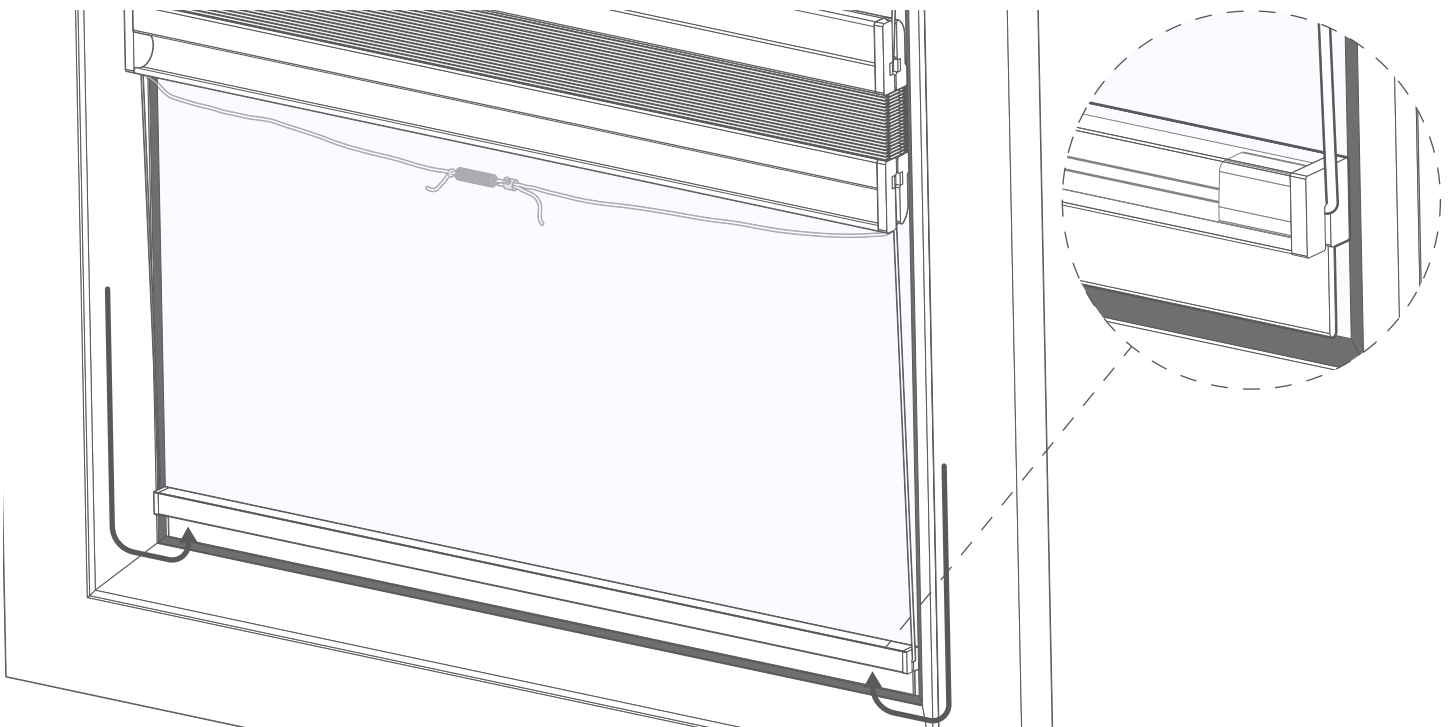

Finally, take the bottom cord and loop it under the bottom rail, so that the cord rests in the notches at the ends of the rail. Try to keep the spring to which the ends of the cords are attached in roughly the centre of the window. The cords and spring should tuck neatly behind the bottom bar.

Additional Information

Adjusting the cord tension (optional)

If you find that the blind does not stay in position when fully raised and begins to slip down, this usually means that there isn't quite enough tension in the blind's cords to hold it up. Increasing the tension is easy to do and will usually resolve the problem.

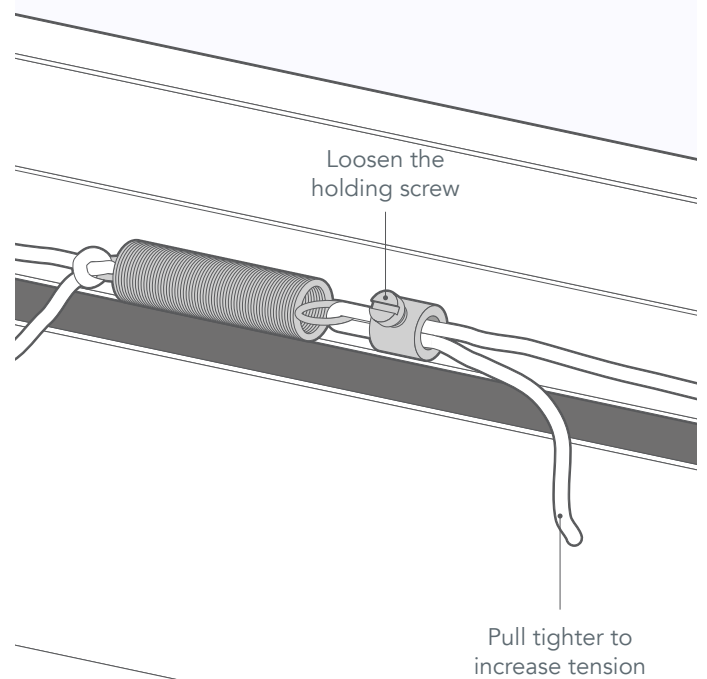
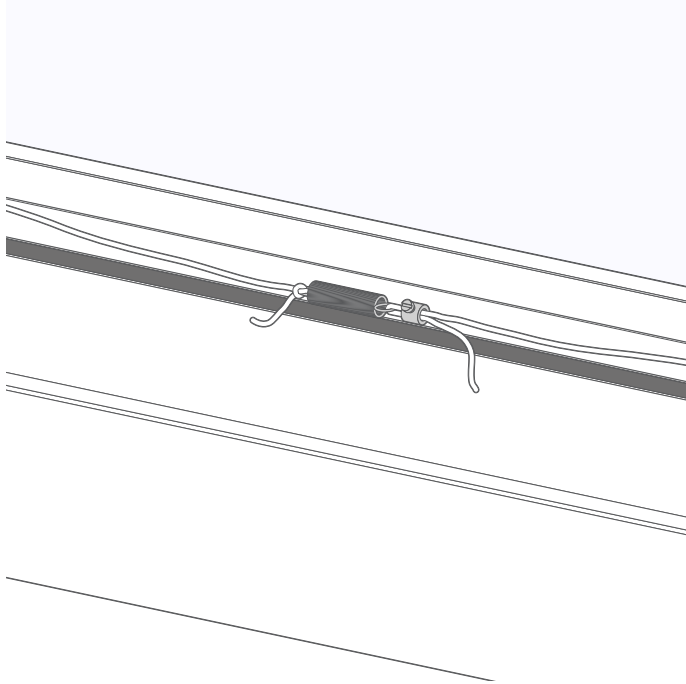

Pull out the spring from behind the bottom bar. One side will be tied to the spring, whilst the other is secured by a holding screw. Hold onto the cords that are secured by the screw, and loosen the screw so that the cords can move. Pull the end of the cord through (away from the spring) to increase the cord tension - only make a small adjustment to start, pulling through roughly 10mm of cord, then tighten the holding screw. Test the blind by fully raising it, to see if it stays in position. If it does then the tension is correct; if it does not, simply add another small amount of tension and try again. Repeat until the tension is correct, then tuck the cord and spring back behind the bottom rail when you're finished.